



TAMCO TOOLS

PRODUCTS

DOBCO
EQUIPMENT LTD

Toll-Free 1-866-763-6226 Phone: 905-672-5557

Fax: 905-672-5559 Email: sales@dobcoeqp.com

Electric Demo Steel

Chipping Hammer Steel

Rivet Buster Steel

Weld Flux Scaler Steel

Drill Steel

Carbide/Steel Rock Bits

Carbide Hollow Drills

Handled Tools

Hand Tools

Maintenance Bars

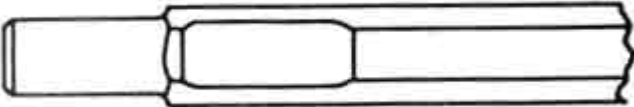
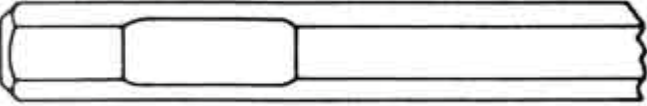

ELECTRIC DEMO HAMMER ACCESSORIES

	Tool Number	Description	Length Overall
	44-01811T	Chisel 1" Blade	12"
	44-01812T	Chisel 1" Blade	18"
	44-01813T	Moil Point	12"
	44-01814T	Moil Point	18"
	44-01817T	Scaling Chisel 2" Blade	12"
	44-01819T	Scaling Chisel 2" Blade	18"
	44-01810T	Scaling Chisel 3" Blade	12"
	44-01818T	Bush Shank Only	7"
	44-01809T	Bush Tool-One Pc.	9"
Above tools fit: Bosch 11306, Hitachi H45SB, Kango 950S, Ramset 442, 445, 475, plus all equivalent models.			
	Tool Number	Description	Length Overall
	44-01517T	Chisel 1" Blade	12"
	44-01518T	Chisel 1" Blade	20"
	44-01515T	Moil	12"



		Point	
	44-01516T	Moil Point	20"
	44-01529T	Scaling Chisel 2" Blade	12"
	44-01503T	Scaling Chisel 3" Blade	12"
	44-01508T	Bush Shank Only	7"
	44-01520T	Bush Tool-One Pc.	9"

Above tools fit: Bosch 11305, Kango 900S, B & D 5021K, plus all equivalent models.

	Tool Number	Description	Length Overall
	44-630009	Moil Point	16"
	44-630010	Chisel 3/4" Blade	16"
	44-631003	Chisel 1-1/2" Blade	11"

Above tools fit: Bosch 11307

	Tool Number	Description	Length Overall
	HLTI-1813	Moil Point	12"
	HLTI-1814	Moil Point	18"
	HLTI-1811	Chisel 7/8" Blade	12"
	HLTI-1812	Chisel 7/8" Blade	18"



	HLTI-1820	Seam Chisel, Angled 1-1/8" Wide	15"
	HLTI-1817	Scaling Chisel 2" Blade	12"
	HLTI-1829	Scaling Chisel 2" Blade	18"
	HLTI-1821	Slotting Chisel, 5 Tooth	12"
	HLTI-1818	Bush Shank Only	7"
	HLTI-1809	Bush Tool-One Pc.	9"

Above tools fit: Hilti TE-52, 60, 72, 92

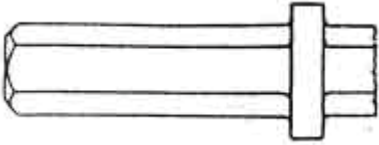
	Tool Number	Description	Length Overall
	44-022763	Moil Point	15"
	44-022763	Chisel 1" Blade	15"
	44-022763	Scaling Chisel	15"

Above tools fit: Wacker EHB10, 110

	Tool Number	Description	Length Overall
	KGO120019	Chisel 1-1/8" Blade	18"
	KGO130019	Moil Point	18"
	KGO001040	Bush Shank Only	8"

Above tools fit: Kango 900, 905

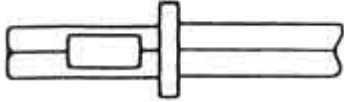

<p>BOSCH BRUTE</p> 	Tool Number	Description	Length Overall
	44-02161T	Moil Point	20-1/2"
	44-02163T	Narrow Chisel	20-1/2"
	44-02164T	Chisel 3" Blade	20-1/2"
	44-02167T	Asphalt Cutter 5"	18"

Above tools fit Bosch 11304

	Tool Number	Description	Length Overall
	44-01909T	Bush Tool - 16 Teeth	9"
	44-01910T	Scaling Chisel 3" Blade	12"
	44-01911T	Chisel, 1" Blade	12"
	44-01912T	Chisel, 1" Blade	18"
	44-01913T	Moil Point	12"
	44-01914T	Moil Point	18"
	44-01917T	Scaling Chisel, 2" Blade	12"

Above tools fit Hilti TE54, TE74, Bosch 11227E, 11230EVS, 11231EVS, 11223EVS, 11313EVS, 11311EVS, 11312E, 11214EVS, 11216EVS, 11309EVS, plus many other makes and models.



CHIPPING HAMMER CHISEL INDEX	
.680 Round Shank Non-Retainer	
.580 Hex Shank Non-Retainer	
.680 Round Shank Oval Retainer	
.580 Hex Shank Oval Retainer	
.680 Round Shank Round Retainer	
.580 Hex Shank Round Retainer	
See Shank Styles below for more details!	

**.680 ROUND SHANK
NON-RETAINER**

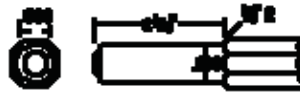

POINT STYLES		BODY STOCK SIZE	TAMCO TOOL NUMBER - LENGTH						
			8"	9"	12"	18"	24"	36"	48"
CHISEL BLANK		3/4"	1000-007	1000-008	1000-011	1000-017	1000-023	1000-035	1000-047
		7/8"	1100-007	1100-008	1100-011	1100-017	1100-023	1100-035	1100-047
FLAT CHISEL		3/4"	1001-008	1001-009	1001-012	1001-018	1001-024	1001-036	1001-048
		7/8"	1101-008	1101-009	1101-012	1101-018	1101-024	1101-036	1101-048
WIDE FLAT CHISEL		3/4"	1005-008	1005-009	1005-012	1005-018	1005-024	1005-036	1005-048
		7/8"	1107-008	1107-009	1107-012	1107-018	1107-024	1107-036	1107-048
BULL or MOIL POINT		3/4"	1011-008	1011-009	1011-012	1011-018	1011-024	1011-036	1011-048
		7/8"	1111-008	1111-009	1111-012	1111-018	1111-024	1111-036	1111-048



Additional Point Styles and Longer Lengths Available Upon Request.

**.580 HEX SHANK
NON-RETAINER**



POINT STYLES		BODY STOCK SIZE	TAMCO TOOL NUMBER - LENGTH						
			8"	9"	12"	18"	24"	36"	48"
CHISEL BLANK		3/4" 7/8"	1200-007	1200-008	1200-011	1200-017	1200-023	1200-035	1200-047
			1300-007	1300-008	1300-011	1300-017	1300-023	1300-035	1300-047
FLAT CHISEL		3/4" 7/8"	1201-008	1201-009	1201-012	1201-018	1201-024	1201-036	1201-048
			1301-008	1301-009	1301-012	1301-018	1301-024	1301-036	1301-048
OFFSET FLAT CHISEL		3/4" 7/8"	1202-008	1202-009	1202-012	1202-018	1202-024	1202-036	1202-048
			1302-008	1302-009	1302-012	1302-018	1302-024	1302-036	1302-048
SIDECUT CHISEL		3/4" 7/8"	1203-008	1203-009	1203-012	1203-018	1203-024	1203-036	1203-048
			1303-008	1303-009	1303-012	1303-018	1303-024	1303-036	1303-048
WIDE FLAT CHISEL		3/4" 7/8"	1205-008	1205-009	1205-012	1205-018	1205-024	1205-036	1205-048
			1307-008	1307-009	1307-012	1307-018	1307-024	1307-036	1307-048
RIPPER CHISEL		3/4" 7/8"	1225-008	1225-009	1225-012	1225-018	1225-024	1225-036	1225-048
			1325-008	1325-009	1325-012	1325-018	1325-024	1325-036	1325-048
BULL or MOIL POINT		3/4" 7/8"	1211-008	1211-009	1211-012	1211-018	1211-024	1211-036	1211-048
			1311-008	1311-009	1311-012	1311-018	1311-024	1311-036	1311-048

Additional Point Styles and Longer Lengths Available Upon Request.

**.680 ROUND SHANK
OVAL RETAINER**







POINT STYLES		BODY STOCK SIZE	TAMCO TOOL NUMBER - LENGTH						
			9"	12"	18"	24"	36"	48"	60"
CHISEL BLANK		13/16"	1400-008	1400-011	1400-017	1400-023	1400-035	1400-047	1400-059
FLAT CHISEL		13/16"	1401-009	1401-012	1401-018	1401-024	1401-036	1401-048	1401-060
OFFSET FLAT CHISEL		13/16"	1402-009	1402-012	1402-018	1402-024	1402-036	1402-048	1402-060
SIDECUT CHISEL		13/16"	1403-009	1403-012	1403-018	1403-024	1403-036	1403-048	1403-060
WIDE FLAT CHISEL		2" PT	1407-009	1407-012	1407-018	1407-024	1407-036	1407-048	1407-060
		3" PT		1442-012					
RIPPER CHISEL		13/16"	1425-009	1425-012	1425-018	1425-024	1425-036	1425-048	1425-060
BULL or MOIL POINT		13/16"	1411-009	1411-012	1411-018	1411-024	1411-036	1411-048	1411-060

Additional Point Styles and Longer Lengths Available Upon Request.

**.580 HEX SHANK
OVAL RETAINER**

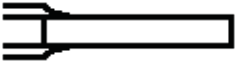

POINT STYLES		BODY STOCK SIZE	TAMCO TOOL NUMBER - LENGTH						
			9"	12"	18"	24"	36"	48"	60"
CHISEL BLANK		13/16"	1500-008	1500-011	1500-017	1500-023	1500-035	1500-047	1500-059
FLAT CHISEL		13/16"	1501-009	1501-012	1501-018	1501-024	1501-036	1501-048	1501-060





OFFSET FLAT CHISEL		13/16"	1502-009	1502-012	1502-018	1502-024	1502-036	1502-048	1502-060
SIDECUT CHISEL		13/16"	1503-009	1503-012	1503-018	1503-024	1503-036	1503-048	1503-060
WIDE FLAT CHISEL		2" PT	1507-009	1507-012	1507-018	1507-024	1507-036	1507-048	1507-060
		3" PT		1542-012					
RIPPER CHISEL		13/16"	1525-009	1525-012	1525-018	1525-024	1525-036	1525-048	1525-060
BULL or MOIL POINT		13/16"	1511-009	1511-012	1511-018	1511-024	1511-036	1511-048	1511-060



Additional Point Styles and Longer Lengths Available Upon Request.

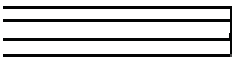

**.680 ROUND SHANK
ROUND RETAINER**

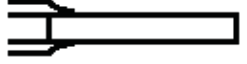

POINT STYLES		BODY STOCK SIZE	TAMCO TOOL NUMBER - LENGTH						
			9"	12"	18"	24"	36"	48"	60"
CHISEL BLANK		13/16"	1600-008	1600-011	1600-017	1600-023	1600-035	1600-047	1600-059
FLAT CHISEL		13/16"	1501-009	1601-012	1601-018	1601-024	1601-036	1601-048	1601-060
OFFSET FLAT CHISEL		13/16"	1602-009	1602-012	1602-018	1602-024	1602-036	1602-048	1602-060
SIDECUT CHISEL		13/16"	1603-009	1603-012	1603-018	1603-024	1603-036	1603-048	1603-060
WIDE FLAT CHISEL		2" PT	1607-009	1607-012	1607-018	1607-024	1607-036	1607-048	1607-060
		3" PT		1642-012					







RIPPER CHISEL		13/16"	1625-009	1625-012	1625-018	1625-024	1625-036	1625-048	1625-060
BULL or MOIL POINT		13/16"	1611-009	1611-012	1611-018	1611-024	1611-036	1611-048	1611-060

Additional Point Styles and Longer Lengths Available Upon Request.

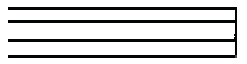
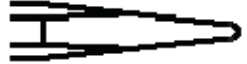

**.580 HEX SHANK
ROUND RETAINER**

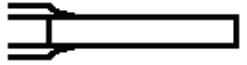

POINT STYLES		BODY STOCK SIZE	TAMCO TOOL NUMBER - LENGTH						
			9"	12"	18"	24"	36"	48"	60"
CHISEL BLANK		13/16"	1700-008	1700-011	1700-017	1700-023	1700-035	1700-047	1700-059
FLAT CHISEL		13/16"	1701-009	1701-012	1701-018	1701-024	1701-036	1701-048	1701-060
OFFSET FLAT CHISEL		13/16"	1702-009	1702-012	1702-018	1702-024	1702-036	1702-048	1702-060
SIDECUT CHISEL		13/16"	1703-009	1703-012	1703-018	1703-024	1703-036	1703-048	1703-060
WIDE FLAT CHISEL		2" PT	1707-009	1707-012	1707-018	1707-024	1707-036	1707-048	1707-060
		3" PT		1742-012					
RIPPER CHISEL		13/16"	1725-009	1725-012	1725-018	1725-024	1725-036	1725-048	1725-060
BULL or MOIL POINT		13/16"	1711-009	1711-012	1711-018	1711-024	1711-036	1711-048	1711-060

Additional Point Styles and Longer Lengths Available Upon Request.





RIVET BUSTER STEEL

SMALL BUSTERS

80X



POINT STYLES	TAMCO TOOL NUMBER - LENGTH					
	RIVET SIZE	9"	12"	18"	24"	36"
CHISEL BLANK 		3200-008	3200-011	3200-017	3200-023	3200-035
FLAT CHISEL 	FORGED ON FLATS	3201-009	3201-012	3201-018	3201-024	3201-036
SIDECUT CHISEL 	FORGED ON FLATS	3203-009	3203-012	3203-018	3203-024	3203-036
BULL or MOIL 		3211-009	3211-012	3211-018	3211-024	3211-036
RIPPER 		3258-009	3258-012			
BACKOUT PUNCH 	3/8"	3260-009	SLEEVES, BUMPERS & SPRINGS Upper Sleeve T33210100			
	1/2"	3261-				

		009	Lower Sleeve	T33210300
	5/8"	3262-009	Rubber Bumper	T33210400
	3/4"	3263-009	Lock Spring	T33219400
	7/8"	3264-009	<p>TAMCO Rivet Buster Tools are designed for use on both metal and concrete. However, for best results, consult your TAMCO representative concerning your specific application.</p>	
4" LONG CLEARANCE BACKOUT 	5/8"	3270-010		
	3/4"	3271-010		
	7/8"	3272-010		
6" LONG CLEARANCE BACKOUT 	5/8"	3273-012		
	3/4"	3274-012		
	7/8"	3275-012		
8" LONG CLEARANCE BACKOUT 	5/8"	3276-014		
	3/4"	3277-014		
	7/8"	3278-014		







JUMBO BUSTERS







11X





POINT STYLES	TAMCO TOOL NUMBER - LENGTH															
	RIVET SIZE	9"	12"	18"	24"	36"										
CHISEL BLANK 		3300-008	3300-011	3300-017	3300-023	3300-035										
FLAT CHISEL 	FORGED ON FLATS	3301-009	3301-012	3301-018	3301-024	3301-036										
SIDECUT CHISEL 	FORGED ON FLATS	3303-009	3303-012	3303-018	3303-024	3303-036										
BULL or MOIL 		3311-009	3311-012	3311-018	3311-024	3311-036										
RIPPER 		3358-009	3358-012													
BACKOUT PUNCH 	3/8"	3360-009	<table border="1"> <thead> <tr> <th colspan="2">SLEEVES, BUMPERS & SPRINGS</th> </tr> </thead> <tbody> <tr> <td>Upper Sleeve</td> <td>T32150200</td> </tr> <tr> <td>Lower Sleeve</td> <td>T32150400</td> </tr> <tr> <td>Rubber Bumper</td> <td>T32150500</td> </tr> <tr> <td>Lock Spring</td> <td>T32019400</td> </tr> </tbody> </table> <p>TAMCO Rivet Buster Tools are designed for use on both metal and concrete. However, for best</p>				SLEEVES, BUMPERS & SPRINGS		Upper Sleeve	T32150200	Lower Sleeve	T32150400	Rubber Bumper	T32150500	Lock Spring	T32019400
	SLEEVES, BUMPERS & SPRINGS															
	Upper Sleeve	T32150200														
	Lower Sleeve	T32150400														
	Rubber Bumper	T32150500														
Lock Spring	T32019400															
1/2"	3361-009															
5/8"	3362-009															
3/4"	3363-009															
7/8"	3364-009															

	1"	3365-009	results, consult your TAMCO representative concerning your specific application.
4" LONG CLEARANCE BACKOUT 	5/8"	3370-010	
	3/4"	3371-010	
	7/8"	3372-010	
6" LONG CLEARANCE BACKOUT 	5/8"	3373-012	
	3/4"	3374-012	
	7/8"	3375-012	
8" LONG CLEARANCE BACKOUT 	5/8"	3376-014	
	3/4"	3377-014	
	7/8"	3378-014	





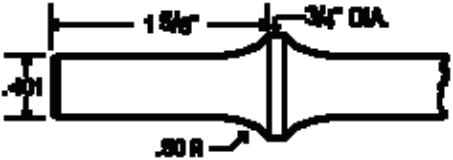

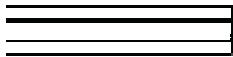

SCALING CHISEL INDEX	
CLECO	
I.R. (INGERSOLL-RAND)	
C.P. (CHICAGO PNEUMATIC)	
.401 PARKER TAPER	
Click any of the above Shank Styles for more details!	

CLECO STYLE SHANK
Cleco B1, B1-A, B1-BV, B1-AJ
Rotor S1 C.P. 9356, I.R. 183 ARO



POINT STYLES	TAMCO TOOL NUMBER - LENGTH						
	7"	9"	12"	18"	24"	36"	48"
CHISEL BLANK 	1800-007	1800-009	1800-012	1800-018	1800-024	1800-036	1800-048



STANDARD WIDE SCALER								
		1851-007	1851-009	1851-012	1851-018	1851-024	1851-036	1851-048
WIDE SCALER 	2"	1807-007		1807-012	1807-018	1807-024	1807-036	1807-048
	2-1/2"	1808-007		1808-012	1808-018	1808-024	1808-036	1808-048
	3"	1842-007		1842-012	1842-018	1842-024	1842-036	1842-048
NARROW SCALER 		1853-007	1853-009	1853-012	1853-018	1853-024	1853-036	1853-048
SPOON SCALER 		1854-007	1854-009	1854-012	1854-018	1854-024	1854-036	1854-048

Additional Point Styles and Longer Lengths Available Upon Request.

INGERSOLL-RAND STYLE SHANK

I.R. 171, 172, 181, 182

Rotor S10 Gardner Denver



1/2" Quarter Octagon Body

POINT STYLES	TAMCO TOOL NUMBER - LENGTH						
	7"	9"	12"	18"	24"	36"	48"
CHISEL BLANK	2000-007	2000-009	2000-012	2000-018	2000-024	2000-036	2000-048



STANDARD WIDE SCALER 									
		2051-007	2051-009	2051-012	2051-018	2051-024	2051-036	2051-048	
WIDE SCALER 		2"	2007-007		2007-012	2007-018	2007-024	2007-036	2007-048
		2-1/2"	2008-007		2008-012	2008-018	2008-024	2008-036	2008-048
		3"	2042-007		2042-012	2042-018	2042-024	2042-036	2042-048
NARROW SCALER 									
		2053-007	2053-009	2053-012	2053-018	2053-024	2053-036	2053-048	
SPOON SCALER 									
		2054-007	2054-009	2054-012	2054-018	2054-024	2054-036	2054-048	

Additional Point Styles and Longer Lengths Available Upon Request.

CHICAGO PNEUMATIC STYLE SHANK





C.P. 455, 456, 457, 458,
Thor 5, 7 Dallet RS3L-A, RS4L-A

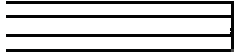

1/2" Quarter Octagon Body

POINT STYLES	TAMCO TOOL NUMBER - LENGTH
---------------------	-----------------------------------



		7"	9"	12"	18"	24"	36"	48"
CHISEL BLANK 		2100-007	2100-009	2100-012	2100-018	2100-024	2100-036	2100-048
STANDARD WIDE SCALER 		2051-007	2151-009	2151-012	2151-018	2151-024	2151-036	2151-048
WIDE SCALER 	2"	2107-007		2107-012	2107-018	2107-024	2107-036	2107-048
	2-1/2"	2108-007		2108-012	2108-018	2108-024	2108-036	2108-048
	3"	2142-007		2142-012	2142-018	2142-024	2142-036	2142-048
NARROW SCALER 		2153-007	2153-009	2153-012	2153-018	2153-024	2153-036	2153-048
SPOON SCALER 		2154-007	2154-009	2154-012	2154-018	2154-024	2154-036	2154-048





Additional Point Styles and Longer Lengths Available Upon Request.

.401 PARKER TAPER SHANK



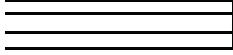

1/2" Round Body

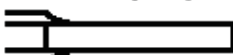
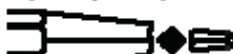
POINT STYLES	ROUND STOCK SIZE	TAMCO TOOL NUMBER - LENGTH			
		7-1/2"	12"	18"	24"
CHISEL BLANK 	1/2"	2200-007	2200-012	2200-018	2200-024
FLAT CHISEL 	1/2"	2201-007	2201-012	2201-018	2201-024
OFFSET FLAT CHISEL 	1/2"	2202-007	2202-012	2202-018	2202-024
SIDECUT CHISEL 	1/2"	2203-007	2203-012	2203-018	2203-024
WIDE FLAT CHISEL 	1/2"	2205-007	2205-012	2205-018	2205-024
RIPPER CHISEL 	1/2"	2225-007	2225-012	2225-018	2225-024
BULL or MOIL POINT 	1/2"	2211-007	2211-012	2211-018	2211-024

Additional Point Styles and Longer Lengths Available Upon Request.



DOBCO
EQUIPMENT LTD

Toll-Free 1-866-763-6226 Phone: 905-672-5557
Fax: 905-672-5559 Email: sales@dobcoeqp.com

HEX HOLLOW DRILL STEEL

"H-THREAD"

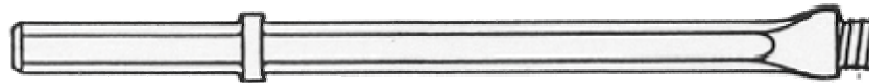

SHANK SIZE	7/8" X 3-1/4" HEX		7/8" X 4-1/4" HEX		1" X 4-1/4" HEX		EXTENSIONS	
	Length Under Collar	Tool No.	Lbs. Each	Tool No.	Lbs. Each	Tool No.	Lbs. Each	Tool No.
1'	44-01414H	3	44-01450H	3-1/4	44-01428H	4	-	-
1-1/2'	44-01415H	4	44-01451H	4-1/4	44-01429H	5	-	-
2'	44-01416H	5	44-01452H	5-1/4	44-01430H	7	44-01430X	7
2-1/2'	44-014161H	6	44-01455H	6-1/4	44-014301H	9	-	-
3'	44-01417H	7	44-01456H	7-1/4	44-01431H	10	44-01431X	10
4'	44-01418H	9	44-01453H	9-1/4	44-01432H	12	44-01432X	12
5'	44-01419H	11	-	-	44-01433H	15	-	-
6'	44-01420H	14	44-01454H	13-1/4	44-01434H	18	44-01434X	18
8'	44-01421H	18	-	-	44-01435H	23	44-01435X	23
10'	44-01422H	22	-	-	44-01436H	28	-	-
12'	44-01423H	26	-	-	44-01437H	34	-	-
14'	44-01424H	30	-	-	44-01438H	39	-	-
16'	44-01425H	35	-	-	44-01439H	45	-	-
18'	44-01426H	39	-	-	44-01440H	50	-	-
20'	44-01427H	43	-	-	44-01441H	55	-	-

SHANK SIZE	3/4" X 3-1/4" HEX		3/4" X 4-1/4" HEX	
Length Under Collar	Tool No.	Lbs. Each	Tool No.	Lbs. Each
6"	-	-	44-01410H	2
8"	44-01400H	2	44-01411H	2-1/4
10"	44-01401H	2-1/4	44-01412H	2-3/4
12"	44-01402H	2-3/4	44-01413H	3
24"	-	-	44-01408H	4-1/2

COUPLINGS AND ADAPTERS

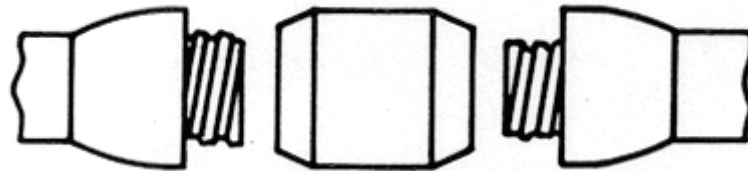

Tool No.	Thread Style	Lbs. Each
44-01504H	H	1/2
44-01507	H-D	3/4

	THREAD	THREAD DIMENSIONS			THREAD
	Series	A	B	C	Per Inch
	D	1.180	1-3/4	.868	5
	E	.623	7/8	.500	6
	H	.998	1-3/8	.711	6



DOBCO
EQUIPMENT LTD

Toll-Free 1-866-763-6226 Phone: 905-672-5557

Fax: 905-672-5559 Email: sales@dobcoeqp.com

HEX HOLLOW DRILL STEEL

{"E", "D", 1" ROPE AND 1-1/4" ROPE THREADS}

Thread Style	E		D		1" Rope		1-1/4" Rope	
Shank Size	7/8" X 3-1/4" Hex		1" X 4-1/4" Hex		1" X 4-1/4" Hex		1" X 4-1/4" Hex	
Length Under Collar	Tool No.	Lbs. Each	Tool No.	Lbs. Each	Tool No.	Lbs. Each	Tool No.	Lbs. Each
1'	44-01414E	2-3/4	44-01428D	4-1/4	-	-	44-01453RT	4-1/4
1-1/2'	44-01415E	3	44-01429D	5-1/2	44-01429RT	5	44-01454RT	5-3/4
2'	44-01416E	3-1/2	44-01430D	6-1/2	44-01430RT	6-1/4	44-01455RT	7
3'	44-01417E	5-3/4	44-01431D	9-1/4	-	-	-	-
4'	44-01418E	8	44-01432D	11	44-01432RT	11	44-01456RT	12-1/2
5'	-	-	-	-	44-01433RT	14-1/2	-	-
6'	-	-	44-01434D	15	44-01434RT	17	44-01457RT	18
8'	-	-	-	-	44-01435RT	22-1/4	44-01458RT	23
10'	-	-	-	-	44-01436RT	27-1/2	-	-
12'	-	-	-	-	44-01437RT	33	-	-



THREADED BITS

ALL STEEL ROCK BITS

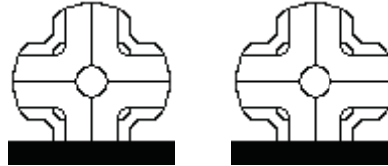

THREAD		E	H	D
DIAMETER MM INCHES		PART NUMBER		
24	15/16"	44-ORB15E		
25	1"	44-ORB16E		
29	1-1/8"	44-ORB18E		
32	1-1/4"	44-ORB20E		
35	1-3/8"		44-ORB22H	
38	1-1/2"		44-ORB24H	
41	1-5/8"		44-ORB26H	
45	1-3/4"		44-ORB28H	44-ORB28D
48	1-7/8"		44-ORB30H	44-ORB30D
51	2"		44-ORB32H	44-ORB32D
57	2-1/4"		44-ORB36H	44-ORB36D
64	2-1/2"		44-ORB40H	44-ORB40D
67	2-5/8"		44-ORB42H	
70	2-3/4"			44-ORB44D
76	3"			44-ORB48D

83	3-1/4"			44-ORB52D
89	3-1/2"			44-ORB56D
102	4"			44-ORB64D



CARBIDE ROCK BITS



THREAD		H		
DIAMETER MM INCHES		CARBIDE HEIGHT	SIZE(HM) WIDTH	PART NUMBER
35	1-3/8"	14	8	HTI-137H
38	1-1/2"	14	8	HTI-150H
41	1-5/8"	14	8	HTI-162H
45	1-3/4"	14	8	HTI-175H
48	1-7/8"	14	8	HTI-187H
51	2"	14	8	HTI-200H
57	2-1/4"	14	8	HTI-225H
64	2-1/2"	14	9.5	HTI-250H
70	2-3/4"	20	12	HTI-275H
76	3"	23	12	HTI-300H





CARBIDE TIPPED HOLLOW DRILLS

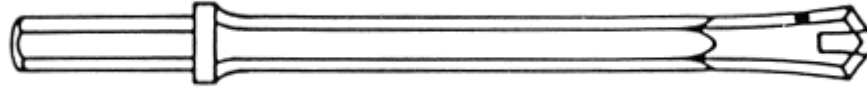

7/8" x 3-1/4" HEXAGON SHANK

TOOL NUMBER	BIT DIAMETER	DRILLING DEPTH	LENGTH UNDER COLLAR
44-03034	5/8"	6"	9"
44-03040	5/8"	9"	12"
44-03033	5/8"	15"	18"
44-030331	5/8"	21"	24"
44-01218	3/4"	6"	9"
44-01219	3/4"	9"	12"
44-01237	3/4"	15"	18"
44-01226	3/4"	21"	24"
44-01228	3/4"	27"	30"
44-00991	7/8"	6"	9"
44-01229	7/8"	9"	12"
44-03038	7/8"	15"	18"
44-00993	7/8"	21"	24"
44-01221	7/8"	27"	30"

44-01230	1"	6"	9"
44-00994	1"	9"	12"
44-03039	1"	15"	18"
44-01232	1"	21"	24"
44-01222	1"	27"	30"
44-00997	1-1/8"	9"	12"
44-00998	1-1/8"	15"	18"
44-01223	1-1/8"	21"	24"
44-01231	1-1/8"	27"	30"
44-00999	1-1/4"	9"	12"
44-01000	1-1/4"	15"	18"
44-01224	1-1/4"	21"	24"
44-03041	1-1/4"	27"	30"
44-03025	1-3/8"	9"	12"
44-03026	1-3/8"	15"	18"
44-03027	1-3/8"	21"	24"
44-03028	1-3/8"	27"	30"
44-03043	1-1/2"	9"	12"
44-03044	1-1/2"	15"	18"
44-03042	1-1/2"	21"	24"
44-03045	1-1/2"	27"	30"



DOBCO
EQUIPMENT LTD

Toll-Free 1-866-763-6226 Phone: 905-672-5557
Fax: 905-672-5559 Email: sales@dobcoeqp.com

3/4" x 3-1/4" HEXAGON SHANK

TOOL NUMBER	BIT DIAMETER	DRILLING DEPTH	LENGTH UNDER COLLAR
44-01216	5/8"	5"	8"
44-00986	3/4"	5"	8"
44-01239	3/4"	12"	15"
44-01240	3/4"	18"	21"
44-01241	3/4"	24"	27"
44-01227	7/8"	5"	8"
44-01233	1"	5"	8"
44-01238	1"	9"	12"
44-01234	1-1/8"	7"	10"
44-01235	1-1/4"	7"	10"

7/8" x 4-1/4" HEXAGON SHANK

TOOL NUMBER	BIT DIAMETER	DRILLING DEPTH	LENGTH UNDER COLLAR
44-01935	5/8"	9"	12"
44-01948	5/8"	15"	18"
44-01950	5/8"	21"	24"
44-01936	3/4"	9"	12"

44-01937	3/4"	15"	18"
44-01951	3/4"	21"	24"
44-01961	3/4"	21"	24"
44-01938	7/8"	9"	12"
44-01939	7/8"	15"	18"
44-01952	7/8"	21"	24"
44-01949	7/8"	27"	30"
44-01940	1"	9"	12"
44-01941	1"	15"	18"
44-01942	1"	21"	24"
44-019421	1"	27"	30"
44-01943	1-1/8"	9"	12"
44-01944	1-1/8"	15"	18"
44-01946	1-1/8"	21"	24"
44-019461	1-1/8"	27"	30"
44-01953	1-1/4"	9"	12"
44-01945	1-1/4"	15"	18"
44-01954	1-1/4"	21"	24"
44-019541	1-1/4"	27"	30"
44-01955	1-3/8"	9"	12"
44-01947	1-3/8"	15"	18"
44-01956	1-3/8"	21"	24"
44-019561	1-3/8"	27"	30"



44-01957	1-1/2"	9"	12"
44-01958	1-1/2"	15"	18"
44-01959	1-1/2"	21"	24"
44-019591	1-1/2"	27"	30"

3/4" x 4-1/4" HEXAGON SHANK

TOOL NUMBER	BIT DIAMETER	DRILLING DEPTH	LENGTH UNDER COLLAR
44-01929	5/8"	5"	8"
44-01930	3/4"	5"	8"
44-01931	7/8"	5"	8"
44-01932	1-1/8"	7"	10"
44-01933	1-3/8"	16"	19"

1" x 4-1/4" HEXAGON SHANK

TOOL NUMBER	BIT DIAMETER	DRILLING DEPTH	LENGTH UNDER COLLAR
44-019621	3/4"	9"	12"
44-01962	3/4"	15"	18"
44-019622	3/4"	21"	24"



DOBCO
EQUIPMENT LTD

Toll-Free 1-866-763-6226 Phone: 905-672-5557
Fax: 905-672-5559 Email: sales@dobcoeqp.com

44-019623	3/4"	21"	24"
44-019624	7/8"	9"	12"
44-019625	7/8"	15"	18"
44-019626	7/8"	21"	24"
44-019627	7/8"	27"	30"
44-01971	1"	9"	12"
44-01972	1"	15"	18"
44-01976	1"	21"	24"
44-01977	1"	27"	30"
44-01973	1-1/8"	9"	12"
44-01974	1-1/8"	15"	18"
44-01978	1-1/8"	21"	24"
44-01979	1-1/8"	27"	30"
44-01989	1-1/4"	9"	12"
44-01980	1-1/4"	15"	18"
44-01981	1-1/4"	21"	24"
44-01982	1-1/4"	27"	30"
44-01990	1-3/8"	9"	12"
44-01983	1-3/8"	15"	18"
44-01984	1-3/8"	21"	24"
44-01985	1-3/8"	27"	30"
44-01991	1-1/2"	9"	12"

44-01986	1-1/2"	15"	18"
44-01987	1-1/2"	21"	24"
44-01988	1-1/2"	27"	30"
44-03050	1-3/4"	21"	24"





SLEDGE HAMMERS & OTHER HANDLED TOOLS	
DOUBLE FACED SLEDGE HAMMERS	
HANDLED TOOLS	
Click any of the above product lines for more details!	

DOUBLE FACED SLEDGE HAMMERS

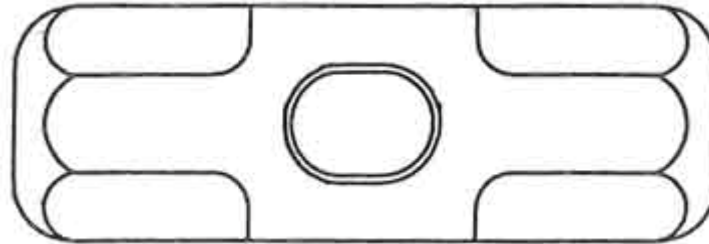

A.R.E.A. PLAN 13-83
ALLOY STEEL - GRADE B

"BT" = TOOL HEAD ONLY
"HT" = TOOL HEAD WITH WOODEN HANDLE
"ST" = TOOL HEAD WITH FIBERGLASS HANDLE

TAMCO TOOL NUMBER	TOOL SIZE	EYE SIZE	HANDLE LENGTH	WEIGHT EACH
BT-10201	1#	5/8" x 7/8"	-	1#
HT-10201			15"	1-1/2#



ST-10201			12"	1-3/4#
BT-10251	1-1/2#	5/8" x 7/8"	-	1-1/2#
HT-10251			15"	2#
ST-10251			12"	2-1/4#
BT-10202	2#	3/4" x 1"	-	2#
HT-10202			16"	2-1/2#
ST-10202			14"	2-3/4#
BT-10252	2-1/2#	3/4" x 1"	-	2-1/2#
HT-10252			16"	3#
ST-10252			14"	3-1/4#
BT-10203	3#	3/4" x 1"	-	3#
HT-10203			16"	3-1/2#
ST-10203			14"	3-3/4#
BT-10204	4#	3/4" x 1"	-	4#
HT-10204			16"	4-1/2#
ST-10204			14"	4-3/4#
BT-10206	6#	1" x 1-3/8"	-	6#
HT-10206			36"	6-1/2#
ST-10206			34"	6-3/4#
BT-10208	8#	1" x 1-3/8"	-	8#
HT-10208			36"	8-1/2#
ST-10208			34"	8-3/4#
BT-10210	10#	1" x 1-3/8"	-	10#
HT-10210			36"	10-1/2#
ST-10210			34"	10-3/4#
BT-10212	12#	1" x 1-3/8"	-	12#
HT-10212			36"	12-1/2#
ST-10212			34"	12-3/4#



BT-10216	16#	1" x 1-3/8"	-	16#
HT-10216			36"	16-1/2#
ST-10216			34"	16-3/4#
BT-10220	20#	1-1/4" x 1-1/2"	-	20#
HT-10220			36"	20-1/2#
ST-10220			34"	20-3/4#

[Click here to return to the Sledge Hammers & Other Handled Tools Index!](#)

HANDLED TOOLS

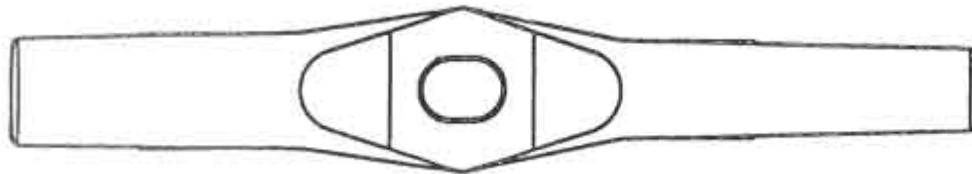

SPIKE MAUL
BELL PATTERN
A.R.E.A. PLAN 3 -- 83
ALLOY STEEL -- GRADE B

TAMCO TOOL NUMBER	TOOL SIZE	EYE SIZE	HANDLE LENGTH	WEIGHT EACH
BT-11010	10#	1" x 1-3/8"	-	10#
HT-11010			36"	10-1/2#
ST-11010			34"	10-3/4#

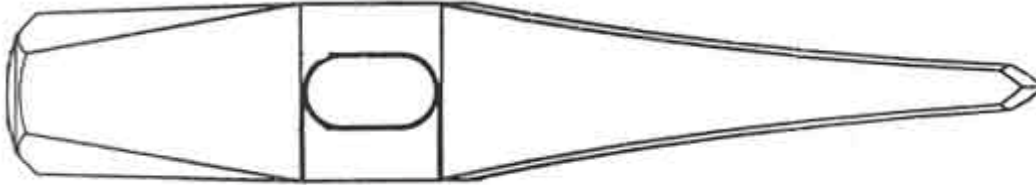

TRACK CHISEL
A.R.E.A. PLAN 17 -- 83
ALLOY STEEL -- GRADE B

TAMCO TOOL NUMBER	TOOL SIZE	EYE SIZE	HANDLE LENGTH	WEIGHT EACH
BT-11500	-	3/4" x 1-3/8"	-	5-1/2#
HT-11500			24"	6#

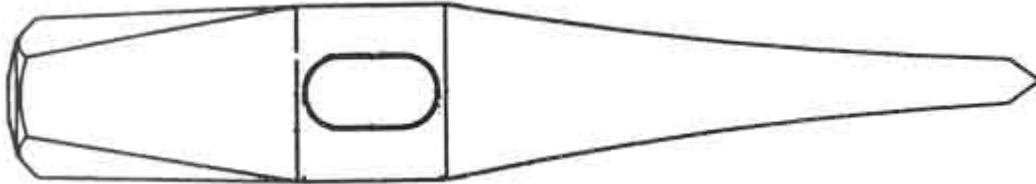

NUT SPLITTER
A.R.E.A. PLAN 35 -- 83
ALLOY STEEL -- GRADE B

TAMCO TOOL NUMBER	TOOL SIZE	EYE SIZE	HANDLE LENGTH	WEIGHT EACH
BT-12000	-	3/4" x 1-3/8"	-	5-1/2#
HT-12000			24"	6#

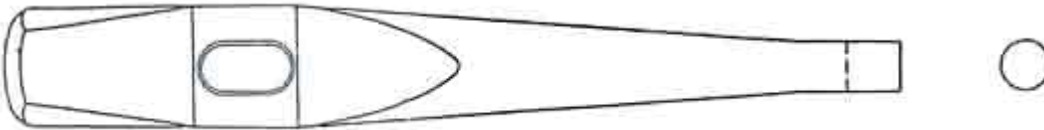

ROUND TRACK PUNCH
A.R.E.A. PLAN 19 -- 83
ALLOY STEEL -- GRADE B

TAMCO TOOL NUMBER	TOOL SIZE	EYE SIZE	HANDLE LENGTH	WEIGHT EACH
BT-12100	-	3/4" x 1-3/8"	-	5-1/2#
HT-12100			24"	6#



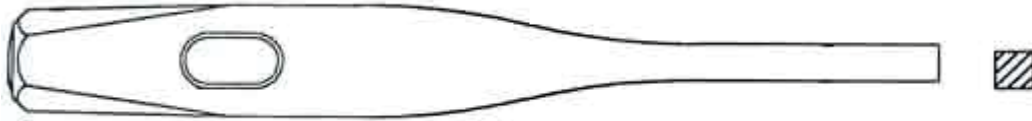

TIE PLUG PUNCH
ALLOY STEEL -- GRADE B

TAMCO TOOL NUMBER	TOOL SIZE	EYE SIZE	HANDLE LENGTH	WEIGHT EACH
BT-12200	-	3/4" x 1-3/8"	-	4#
HT-12200			24"	4-1/2#

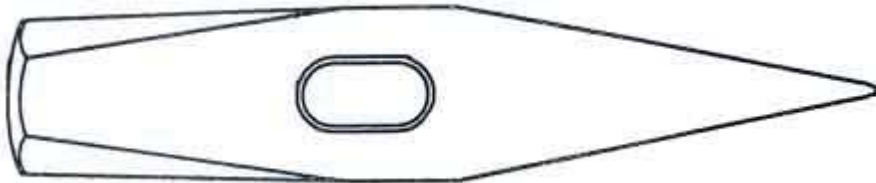

WELDERS CHISELS
3 LB. A.R.E.A. PLAN 36 -- 83
5 LB. A.R.E.A. PLAN 37 -- 83
ALLOY STEEL -- GRADE B

TAMCO TOOL NUMBER	TOOL SIZE	EYE SIZE	HANDLE LENGTH	WEIGHT EACH
BT-10503	3#	3/4" x 1-3/8"	-	3#
HT-10503			36"	3-1/2#
BT-10505	5#	3/4" x 1-3/8"	-	5#
HT-10505			36"	5-1/2#

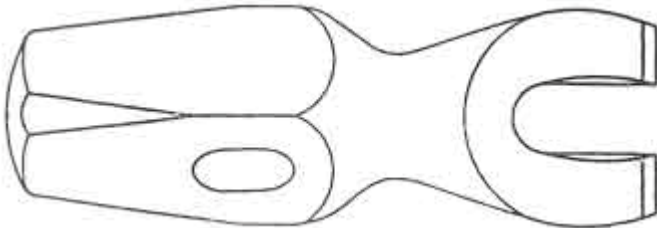

TRACK SPIKE LIFTER
A.R.E.A. PLAN 32 -- 83
ALLOY STEEL -- GRADE B

TAMCO TOOL NUMBER	TOOL SIZE	EYE SIZE	HANDLE LENGTH	WEIGHT EACH
BT-12900	-	1" x 1-3/8"	-	6-1/4#





HT-12900			36"	6-3/4#
ST-12900			34"	7#

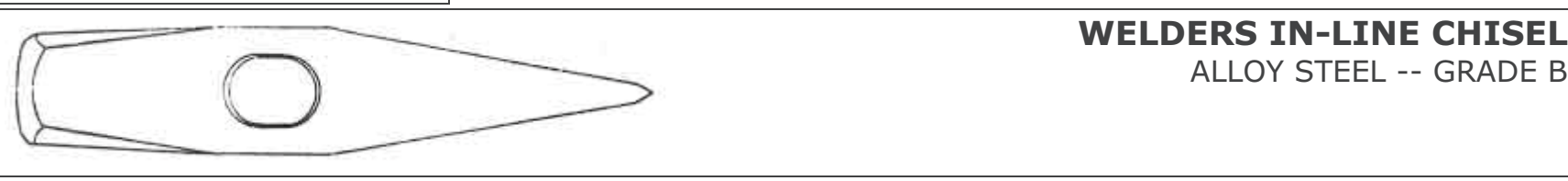

WELDERS IN-LINE CHISEL
ALLOY STEEL -- GRADE B

TAMCO TOOL NUMBER	TOOL SIZE	EYE SIZE	HANDLE LENGTH	WEIGHT EACH
BT-12600	-	1" x 1-3/8"	-	5#
HT-12600			36"	5-1/2#
ST-12600			34"	5-3/4#

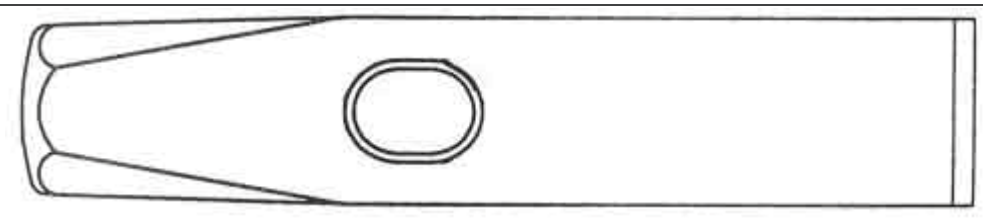

WELDERS CROSS-CUT CHISEL
ALLOY STEEL -- GRADE B

TAMCO TOOL NUMBER	TOOL SIZE	EYE SIZE	HANDLE LENGTH	WEIGHT EACH
BT-12700	-	1" x 1-3/8"	-	5#
HT-12700			36"	5-1/2#
ST-12700			34"	5-3/4#

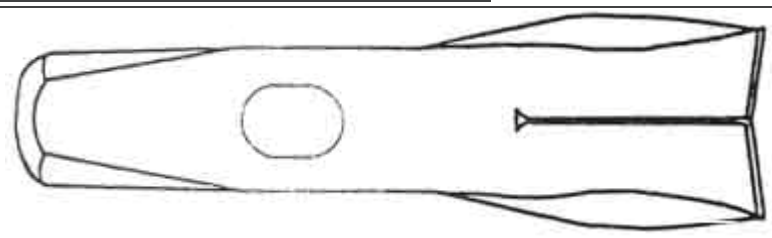

WELDERS V CHISEL
ALLOY STEEL -- GRADE B



TAMCO TOOL NUMBER	TOOL SIZE	EYE SIZE	HANDLE LENGTH	WEIGHT EACH
BT-12800	-	1" x 1-3/8"	-	5#
HT-12800			36"	5-1/2#
ST-12800			34"	5-3/4#

BACKING-OUT PUNCH	TAMCO TOOL NUMBER	PUNCH DIA.	PUNCH LENGTH	OVERALL LENGTH	EYE SIZE	HANDLE LENGTH	WEIGHT EACH	
ALLOY STEEL -- GRADE B	BT-10106	3/8"	2-1/2"	7-1/4"	3/4" x 1"	-	1#	
	HT-10106					16"	1-1/2#	
	ST-10106					14"	1-3/4#	
	BT-10108	1/2"	2-1/2"	7-1/4"	3/4" x 1"	-	1-3/4#	
	HT-10108					16"	2-1/4#	
	ST-10108					14"	2-1/2#	
	 ADDITIONAL PUNCH DIAMETERS AND LENGTHS AVAILABLE	BT-10110	5/8"	2-3/4"	7-3/4"	3/4" x 1"	-	2#
		HT-10110					16"	2-1/4#
		ST-10110					14"	2-3/4#
		BT-10112	3/4"	3"	8"	3/4" x 1"	-	2-1/2#
		HT-10112					16"	3#
		ST-10112					14"	3-1/4#
BT-10114		7/8"	3"	8-1/4"	3/4" x 1"	-	3#	
HT-10114						16"	3-1/2#	
ST-10114						14"	3-3/4#	
BT-10116		1"	3-1/2"	8-1/2"	3/4" x 1"	-	3-1/2#	
HT-10116						16"	4#	



TAMCO
Real Tools. Real Work.

DOBCO
EQUIPMENT LTD

Toll-Free 1-866-763-6226 Phone: 905-672-5557
Fax: 905-672-5559 Email: sales@dobcoeqp.com

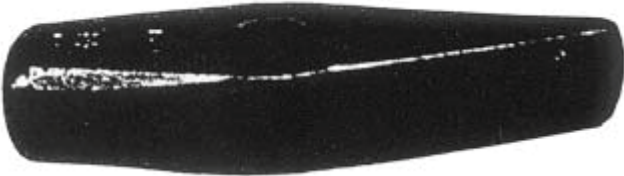
		ST-10116					14"	4-1/4#
COLD CUTTER		TAMCO TOOL NUMBER	TOOL SIZE	BIT SIZE	OVERALL LENGTH	EYE SIZE	HANDLE LENGTH	WEIGHT EACH
<p>ALLOY STEEL -- GRADE B</p> 		BT-10802	2#	1-1/4"	6"	3/4" x 1"	-	2#
		HT-10802					15"	2-1/2#
		ST-10802					14"	2-3/4#
		BT-10803	3#	1-1/2"	7"	3/4" x 1"	-	3#
		HT-10803					16"	3-1/2#
		ST-10803					14"	3-3/4#
		BT-10804	4#	1-1/2"	7-1/2"	3/4" x 1"	-	4#
		HT-10804					16"	4-1/2#
		ST-10804					14"	4-3/4#
		BT-10805	5#	1-3/4"	8"	1" x 1-3/8"	-	5#
		HT-10805					34"	6#
		ST-10805					34"	7#

[Click here to return to the Sledge Hammers & Other Handled Tools Index!](#)



HAND TOOLS MISCELLANEOUS

All hand tools are 100% Magnaflux inspected and have a TAMCO SAF-T HEAD contour grind to withstand mushrooming and spalling.









POINT STYLES		STANDARD SIZES							
		TAMCO TOOL #	H HEIGHT	W WIDTH	L LENGTH	TAMCO TOOL #	H HEIGHT	W WIDTH	L LENGTH
WEDGE		6601-004	1/4"	1/2"	4"	6642-006	3/4"	1"	6"
		6602-006	1/4"	1/2"	6"	6643-012	3/4"	1"	12"
		6611-004	3/8"	3/4"	4"	6651-006	7/8"	1"	6"
		6612-004	3/8"	1"	4"	6661-008	1"	1"	8"
		6621-006	1/2"	3/4"	6"	6662-012	1"	1-1/2"	12"
		6622-007	1/2"	1"	7"	6663-012	1"	3"	12"
		6623-008	1/2"	1-1/2"	8"	6671-010	1-1/2"	2"	10"
		6631-008	5/8"	1-1/4"	8"	6681-008	2"	2"	8"
		6632-006	5/8"	2"	6"	6682-012	2"	2"	12"
		6641-007	3/4"	3/4"	7"	6683-012	2"	3"	12"
BANANA WEDGE		6696-013	13/16"	13/16"				13"	

Wedges can be furnished in other sizes. Specify dimensions.



MAINTENANCE BARS

POINT STYLES	BODY STOCK SIZE	TAMCO TOOL NUMBER - LENGTH						
		12"	18"	24"	36"	48"	60"	72"
PINCH BAR 	1/2" 5/8" 3/4" 7/8" 1"	7001-012 7002-012	7001-018 7002-018 7003-018	7001-024 7002-024 7003-024 7004-024	7002-036 7003-036 7004-036 7005-036	7003-048 7004-048 7005-048	7004-060 7005-060	7004-072 7005-072
PRY BAR 	1/2" 5/8" 3/4" 7/8" 1"	7101-012 7102-012	7101-018 7102-018 7103-018	7101-024 7102-024 7103-024 7104-024	7102-036 7103-036 7104-036 7105-036	7103-048 7104-048 7105-048	7104-060 7105-060	7104-072 7105-072
LINING BAR 	1/2" 5/8" 3/4" 7/8" 1"	7201-012 7202-012	7201-018 7202-018 7203-018	7201-024 7202-024 7203-024 7204-024	7202-036 7203-036 7204-036 7205-036	7203-048 7204-048 7205-048	7204-060 7205-060	7204-072 7205-072
FITTING-UP BAR 	1/2" 5/8" 3/4" 7/8" 1"	7301-012 7302-012	7301-018 7302-018 7303-018	7301-024 7302-024 7303-024 7304-024	7302-036 7303-036 7304-036 7305-036	7303-048 7304-048 7305-048	7304-060 7305-060	7304-072 7305-072
CHISEL BAR 	1/2" 5/8" 3/4" 7/8" 1"	7401-012 7402-012	7401-018 7402-018 7403-018	7401-024 7402-024 7403-024 7404-024	7402-036 7403-036 7404-036 7405-036	7403-048 7404-048 7405-048	7404-060 7405-060	7404-072 7405-072
NEEDLE BAR 	3/4" 7/8" 1"				7503-036	7503-048 7504-048	7503-060 7504-060 7505-060	7504-072 7505-072
GOOSE NECK BAR 	3/4" 7/8" 1"				7603-036	7603-048 7604-048 7605-048	7604-060 7605-060	7605-072



Toll-Free 1-866-763-6226 Phone: 905-672-5557
Fax: 905-672-5559 Email: sales@dobcoeqp.com

Additional Sizes Can Be Furnished. Specify Dimensions.